

STYLE 907 HYBRID SEAL

Cartiridge mounted refillable seal



Fit and forget

No maintenance required



No failure

Simply refill to restore sealing capacity



Efficient, effective

Dry running capability, unaffected by slurries and solids



SEALING BEYOND EXPECTATIONS
Sealing Devices and Industrial Solutions



WHAT ARE THE NEW CHALLENGES THAT INDUSTRY HAS TO FACE FOR THE NEXT DECADES?

Bringing sealing devices to the next age. Keeping safe from future problems that will arise.

SUSTAINABILITY

Processes with lighter environmental footprint will see more and more competitive advantages over companies postponing any serious effort to optimize their impact on the planet. Laws and regulations are becoming stricter day by day, it's only a matter of time until environmental indicators, such as carbon footprints or water consumption, will determine a competitive advantage.

- Industry uses about 12% of all the water supply. With droughts becoming more and more frequent, optimizing

its consumption is one of the main challenges of our time.

- A typical pump with mechanical seals can consume up to 10 gallons of flush water per minute: that is 700,000 ft³ per year, requiring an average energy consumption of 8,300 kWh to be injected. With the average US power mix, this is equal to roughly 7,000 lb of Co2 per year. For one pump only.

- If the same pump uses gland packings with lantern ring, the water consumption can be up to 18 gal per minute, for almost 1,250,000 ft³ per year, and 12,600 lb of Co2.

SELF-SUFFICIENCY

The globalized supply chains that have carried us through the first decades of this century are being jeopardized by new possible geopolitical balances. The best way for a factory to be safe during the turmoils of the raw materials markets is to greatly limit its exposure to such external forces by reducing its consumptions.

- While refurbishing is possible, almost 85% of mechanical seals end up being replaced entirely during maintenance. Every year, tons of steel, ceramic materials and rubber are simply thrown

away during seal maintenance. After having paid for the material that gets thrown away, the factory pays for its disposal too. Energy is consumed for the product manufacturing, and for the waste management.



EFFICIENCY

The focus for factories has been for a long time to fill up their output capacity by finding new markets worldwide. Nowadays, profit margins are shrinking even with production schedules fully booked, and efficiency of processes is becoming the key profit driver: less input for the same output is the new way of maximizing profits.

- A proper sealing is a key driver to generate value through efficiency: machine downtime, leakage, cleaning expenditures and man hours are all true costs that can be controlled with the right technology.

- A 10 gal/min flush line requires a yearly power cost of about USD 1,100 to operate, excluding the cost of water.

Technical Data

pressure Max 4 MPa* (580 PSI)

temperature Max 260°C (500°F) - **STYLE 907HT** up to 550°C (1000°F)

speed Max 25 m/s (4921 FPM)

*Actual pressure limit may vary.



Materials

Sealing compound	Unbleached PTFE, graphite, aramid fibers, food grade PTFE
O-rings	NBR, EPDM, FKM, FEPM, FFKM, graphite
Sleeve coating	Silicon carbide, DLC
Metal parts	1.4571 CrNiMo Steel (316Ti), exotic alloys

Style 907HS "HYBRID SEAL"

This groundbreaking technology is the new evolution of sealing devices: it is such a departure from the traditional mechanical seal, that it can no longer be called by that name only.



Style 907HS brings together the main advantages of both mechanical seals and gland packings, while at the same time eliminating their disadvantages.

THE HARDWARE:

Easy to install cartridge seal unit with low friction components.

THE SOFTWARE:

Injectable self-lubricating sealing compound.

STURDY

Style 907 is not affected by abrasion, corrosion, misalignment, vibration.



Style 907 is easily customizable to be the perfect match for any application.

WHY A "HYBRID SEAL":

Forget the sudden or catastrophic failures of mechanical seals: only gradual leakage that can be fixed without even stopping the pump.

- No leakage, no process fluid required to keep gland packings lubricated.
- No flushing required. Ever. Spare the water, spare the energy to inject it, spare the product dilution. Let water be used where it's really needed!
- No machine downtime for maintenance. No replacement, no refurbishing: only top up at the first sign of leakage.
- No damage for temporary dry running. Sustainable dry running operations at lower speeds.
- No stock of different spare parts for different seal models and sizes: the same spare material can be used for all sizes and conditions.



Style 907 doesn't leak like packings, but dripping can occur.



A simple refill without shutting the line stops the leak.



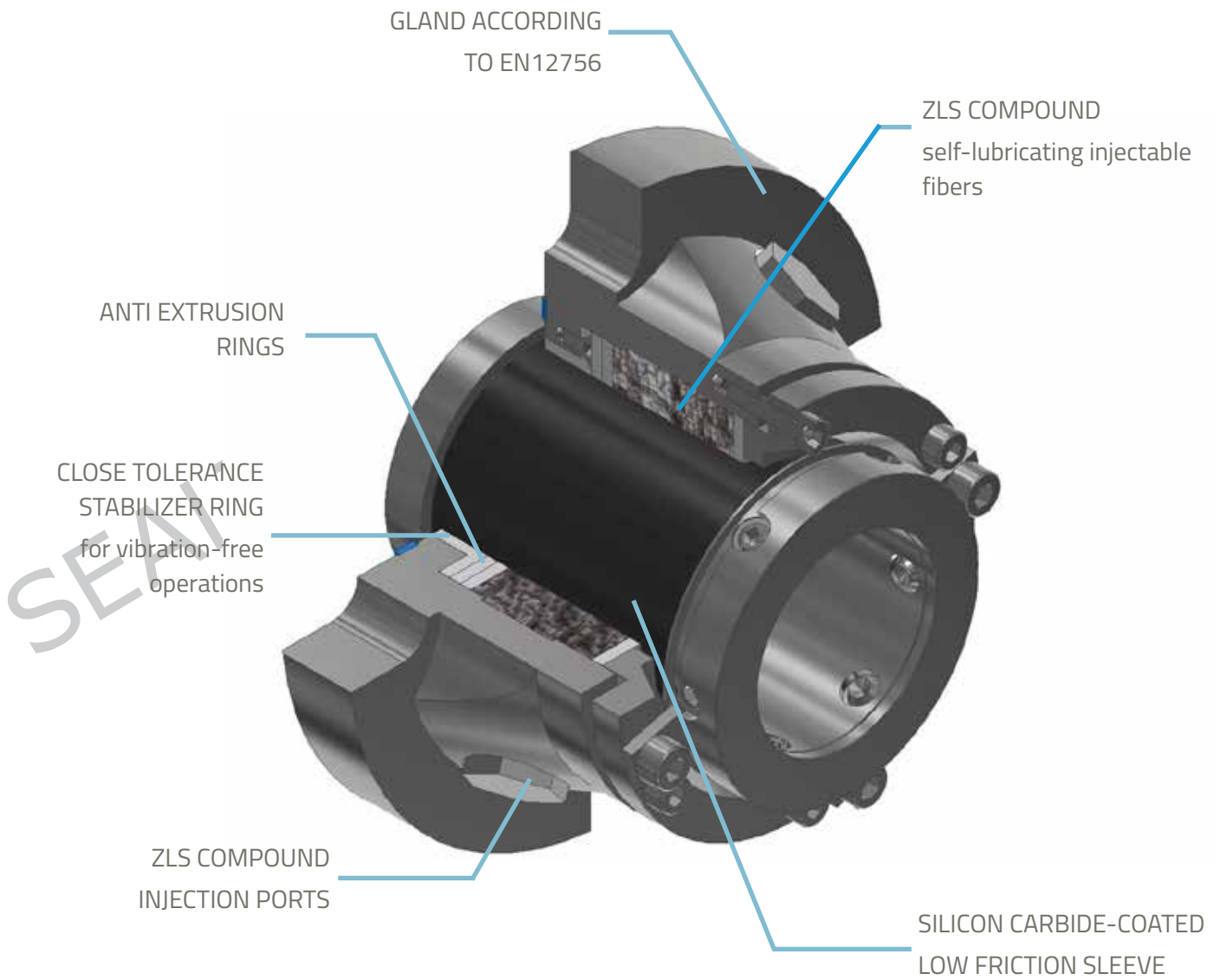

Gland packings	Mechanical seals	Style 907
High leakage	Low leakage	Low leakage
High power absorption	Low power absorption	Low power absorption
Replacement requires shutdown	Replacement requires shutdown	Refill online
Gradual leakage	Sudden failure	Gradual leakage
Spare part required for each size	Spare part required for each size	One spare fits all
Score the shaft	Do not score the shaft	Does not score the shaft
Can't withstand dry running	Can't withstand dry running	Withstands dry running
Lantern ring and flush sometimes required	Flush and barrier sometimes required	No fluid injection required

INJECTORS REFILL KIT

Style 907 is a **full system**, which includes a seal and a refill unit kit.

KIT COMPOSITION

SEALTEK®'s ZLS INJECTION SYSTEM is available with either a high pressure, **A** hand, **B** electric or **C** extra high pressure hand pump, an aerospace grade light alloy cylinder **D**, **E**, a high pressure reinforced rubber hose with special connectors **F** and a set of threaded ball valve heads for installing on to the flush or lantern ring ports of the stuffing box **G**.

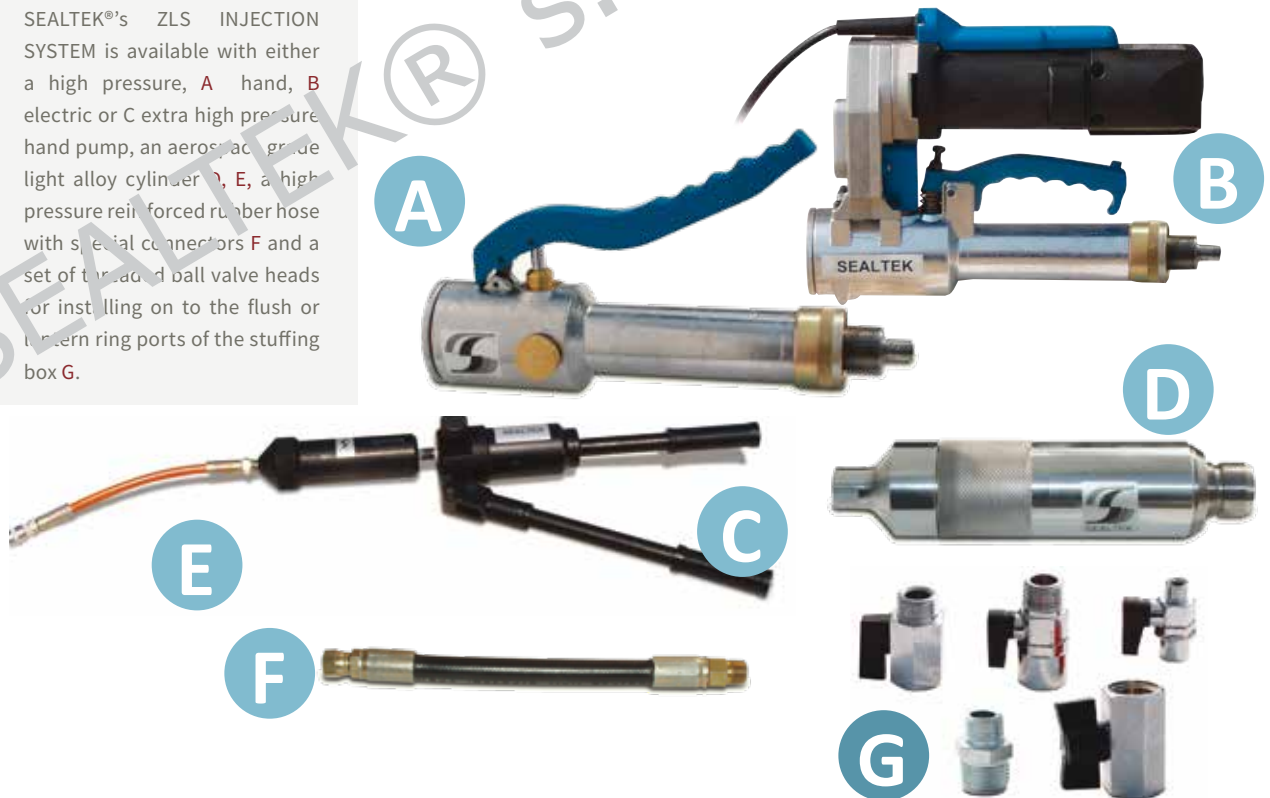

MANUAL INJECTOR

The standard injection gun allows to quickly top up STYLE 907. Just plug the tube to the refill port, and inject until it is no longer possible to do so.



SCREW INJECTOR

Single canisters of ZLS compound can be individually attached to each pump; at the first sight of leakage, simply screw the top until the dripping disappears.

ZERO LEAKAGE SYSTEM COMPOUND

Available materials:

STYLE SEVEN Expanded Graphite

Injectable packing compound designed for heavy duty applications of high temperature and pressure, made of 100% expanded pure graphite. Suitable for steam valves, boiler feed and hot oil pumps, etc.

T °C	-30 ÷ +600
P bar	40
V m/sec	25
pH	0 ÷ 14



STYLE TF350 Unbleached PTFE

Unique chemically resistant compound based on pure PTFE fibers and expanded PTFE pellets, mixed with special tixotropic lubricants. A great sealant achieving easily zero leakage conditions in pumps, valves and other devices with a peripheral speed of up to 8 m/sec. Recommended for use in cryogenic applications. Seals almost all fluids including aggressive chemicals. Does not stain.

T °C	-40 ÷ +260
P bar	20
V m/sec	8
pH	0 ÷ 14



STYLE FIVE PTFE fibers

Injectable packing compound made of virgin PTFE textured fibres and special inert lubricants for extremely high performances.

Meets FDA requirements. Ideal for pumps and valves in food plants, pharmaceutical and chemical industries and drinking water production.

T °C	-80 ÷ +260
P bar	20
V m/sec	8
pH	0 ÷ 14





VARIANTS



550° C Maximum Temperature

STYLE 907ht HIGH TEMPERATURE

No heat exchanger required

This version is loaded with Style Seven graphite fibers, and is equipped with bronze wear parts and graphite gaskets to withstand temperature up to 450°C, with peak resistance of over 550°C.



No leakage

STYLE 907td TOTAL DRY

Advanced sealing action

By replacing wear rings with high performance lip seals, Style 907TD ensures that no leakage can occur. The spring-loaded gland follower allows a visual control over the ZLS level, outlining the need of refills without actual leakage taking place. Particularly suitable when leakage is not allowed.



Mixer seal

STYLE 907mx MIXER SEAL

Double bearing-like rings

This variant is sized for applications on mixers, vessels and machinery according to DIN 28138, DIN28136, DIN 28141 and DIN 28154. Its two stabilizer rings act as the seal's own bearing set, absorbing the radial runout of the shaft. Total dry running capability for top end applications.

STYLE 907 SIZES AND DIMENSION

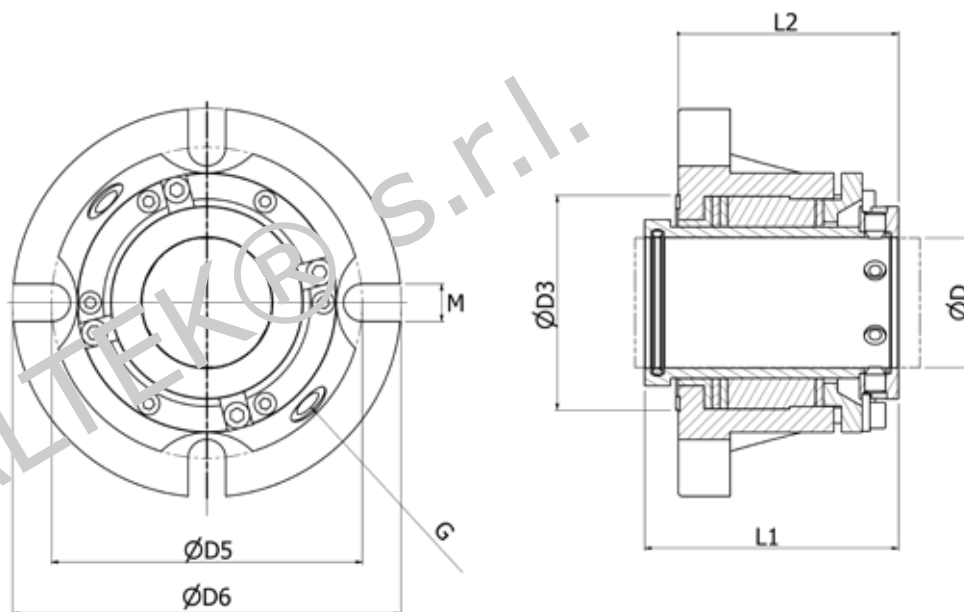

D	In	D3	D5	D6	L1	L2	M	G
24		58,0	80,0	104,0	85,0	73,0	13,0	2 x 3/8 GAS
25	1							
28	1,125	61,5	80,0	104,0	85,0	73,0	13,0	2 x 3/8 GAS
30		63,0	90,0	110,0	85,0	73,0	13,0	2 x 3/8 GAS
32	1,25	65,5	100,0	110,0	85,0	73,0	13,0	2 x 3/8 GAS
33								
35	1,375	68,0	100,0	128,0	85,0	73,0	13,0	2 x 3/8 GAS
38	1,5	72,0	100,0	128,0	85,0	73,0	13,0	2 x 3/8 GAS
40		73,0	100,0	128,0	85,0	73,0	13,0	2 x 3/8 GAS
43	1,625	75,5	106,0	142,0	98,0	85,0	14,0	2 x 3/8 GAS
45	1,75	77,8	106,0	142,0	98,0	85,0	14,0	2 x 3/8 GAS
48	1,875	82,8	120,0	154,0	98,0	85,0	14,0	2 x 3/8 GAS
50	2							
55	2,125	87,0	120,0	172,0	98,0	85,0	14,0	2 x 3/8 GAS
58	2,25	93,0	120,0	172,0	98,0	85,0	17,0	2 x 3/8 GAS
60								
	2,375	101,5	134,0	180,0	98,0	85,0	17,0	2 x 3/8 GAS
65	2,5							
	2,625	108,0	134,0	180,0	98,0	85,0	17,0	2 x 3/8 GAS
70	2,75							
75	2,875	120,5	148,0	200,0	98,0	85,0	19,0	2 x 3/8 GAS
	3							
80	3,125	130,0	148,0	200,0	105,0	91,0	19,0	2 x 3/8 GAS
85	3,25	132,8	160,0	220,0	105,0	91,0	20,0	2 x 3/8 GAS
	3,375							
90	3,5	140,8	160,0	220,0	105,0	91,0	20,0	2 x 3/8 GAS
	3,625							
95		140,5	176,0	240,0	105,0	91,0	20,0	2 x 3/8 GAS
	3,75							
	3,875							
100	4							



SEALTEK srl
 35010 VIGONZA (PD) Italy - Via Germania, 31
 Tel. +39 0498932178 - 8930536
 Fax +39 0498931723
www.sealtek.com - e-mail: info@sealtek.com

SEALTEK® S.r.l.

SEALTEK® S.r.l.